

PROJECT NAME:	TYPE:
----------------------	--------------

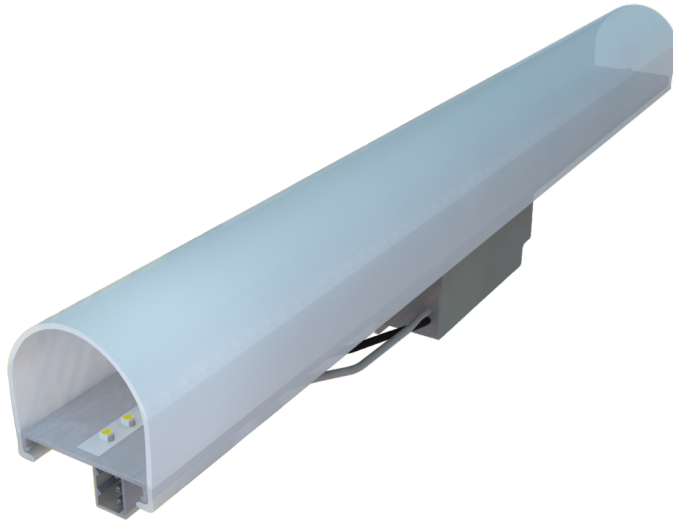

NL-CCF-RL

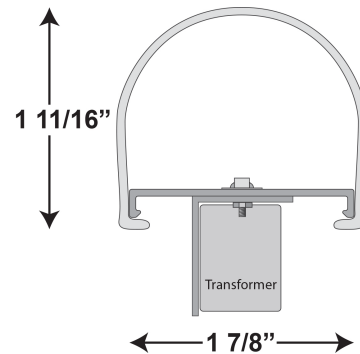

- The Neotek Cold Cathode to LED retrofit fixture is a straight or curved, self-contained light emitting diode fixture replacement for the Neotek CCF fixture (Type CCF). The top has an LED light strip mounted onto a aluminum extrusion with a wiring harness that plugs into the existing base harness. A solid state 24v transformer(s) are mounted into the bottom of the extrusion.
- Extrusion: The extrusion shall be made of aluminum. Extrusion comes standard mill finish, it can also be powder coated with colors.
- LEDs: High output 3528 binned chips, 24v operating. Consuming 3.00 watts per foot and available in colors below. The chips and circuitry are fastened to the extrusion. The strips produce 420 lumens per foot. Angle of illumination is 120 degrees.
- Power Supply: The power supply is a solid state and mounted inside the bottom extrusion. Transformer specifications may change due to the current development of new unit.
- Lens: The lens shall be made of polycarbonate and be frosted or clear.
- All LED linear fixtures are dimmable using various types of dimmers. RGB* can be controlled with any DMX 512 protocol, however assistance is available from Neotek for more specific control solutions.

COLOR OF LED LIGHT:		
<input type="checkbox"/> 24K White <input type="checkbox"/> 28K White <input type="checkbox"/> 30K White <input type="checkbox"/> 35K White <input type="checkbox"/> 40K White <input type="checkbox"/> 65K White <input type="checkbox"/> Red <input type="checkbox"/> Green <input type="checkbox"/> Blue <input type="checkbox"/> Amber <input type="checkbox"/> RGB*		
LENS:	INPUT VOLTAGE:	DIMMING TYPE:
<input type="checkbox"/> Frosted <input type="checkbox"/> Clear	<input type="checkbox"/> 120v <input type="checkbox"/> 277V	<input type="checkbox"/> 0-120VL(LV) <input type="checkbox"/> 0-10V <input type="checkbox"/> None
FIXTURE FINISH:		APPLICATION:
<input type="checkbox"/> Standard Mill <input type="checkbox"/> Black <input type="checkbox"/> Custom		<input type="checkbox"/> Interior IP00 <input type="checkbox"/> Exterior IP67
JOB INFORMATION:		DATE:
		PAGE #:
* RGB will need to be verified by Neotek that the current CCF system can convert to RGB. Neotek will have to be sure there is adequate locations for the DMX control.		